

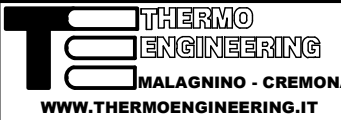

WT	
M	
C	

 <b>THERMO ENGINEERING</b> MALAGNINO - CREMONA WWW.THERMOENGINEERING.IT	<b>TOLLERANZE GENERALI:</b> <small>GENERAL TOLERANCE</small> <b>EN 22768-m</b>		<b>NS. ART.:</b> <b>TES.01.05</b>	<small>OUR CODE:</small>	<b>TE:</b> <small>JOB N°</small>
	<b>DIMENSIONI LINEARI:</b> <small>LINEAR DIMENSIONAL</small> <b>mm</b>		<b>COD. ART. CLIENTE:</b>	<small>CUSTOMER CODE</small>	<b>POS.:</b> <small>ITEM</small>
	<b>SCALE:</b>	<b>FIRST ANGLE</b> 	<b>DESCRIZIONE:</b>	<small>DESCRIPTION</small>	<b>PEZZI:</b> <small>Q.TY.</small>
	<b>REV. / DATA:</b>	<small>REV. / DATE</small>	<b>DISEGNO / DATA:</b>	<small>DRAWING / DATE</small>	<small>PROPRIETA' DI THERMO ENGINEERING S.R.L.          VIETATA LA RIPRODUZIONE NON          AUTORIZZATA          PROPRIETY OF THERMO ENGINEERING S.R.L.          UNAUTHORIZED REPRODUCTION FORBIDDEN</small>